

ZOOMLION TECHNOLOGY WITH INGENUITY AND CARE



THE WORLD'S LEADING EXCAVATOR INTELLIGENT MANUFACTURING FACTORY

ZOOMLION Smart City Earthmoving Machinery Park is an industry-leading intelligent and flexible excavator factory. From a piece of steel plate to an excavator, with high-precision welding process, highly reliable assembly process, high-level coating process and strict quality control, each excavator is delivered with ultimate quality.



ZOOMLION

Zoomlion Heavy Industry Science & Technology Co.,Ltd.

Add: No.361, South Yinpen Road, Changsha, Hunan Province, P.R.China 410013 Email: earthmoving@zoomlion.com
Copyright©2025 Zoomlion. All rights reserved. Reproduction and copying of any part of contents is not allowed for any purposes without Zoomlion's approval.
Note: Materials and specifications are subject to change without notice. Featured machines in photos may include additional equipment.



ZOOMLION 1.8-TONNAGE CRAWLER HYDRAULIC EXCAVATOR

ZE18GU



ZOOMLION

**VISION
CREATES
FUTURE**



ZOOMLION MINI-EXCAVATOR

ZE18GU

Engine power
11.8 kW @ 2300 rpm

Operating weight
1800 kg

Bucket capacity:
0.04 m³



ZOOMLION MINI-EXCAVATOR

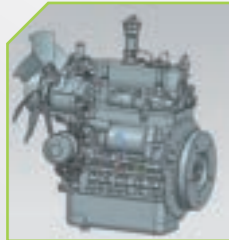

FAMOUS BRAND ENGINE

Famous brand engine with three-vortice combustion system (E-TVCS); Mechanical speed regulation ; High power, sufficient power reserve, fuel saving

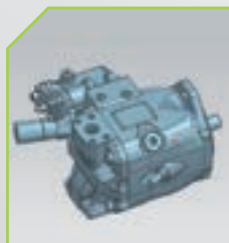

THE NEW-GENERATION OF ZOOMLION MAIN PUMP

The 28cc large-displacement main pump is combined with the large-torque, high-power reserve engine to achieve low fuel consumption and high work efficiency.



VERSATILE ZE18GU

Versatile ZE18GU has powerful performance and features, which can easily meet customer needs. A high configuration model is equipped with a breaker plumbing, a quick coupler plumbing, and multiple attachment plumbings, and allows the user to control the plumbing with a switch on the joystick for easier operation.

ZERO-TAIL SWING



One of ZE18GU's highlights is zero tail swing, its radius of swing will not exceed the width of the track in the full expanded state. This design means that it can work in narrow spaces and on busy roads, not limited by space.



LOAD SENSING SYSTEM

It can provide and distribute the flow according to the needs of the system, which meets the requirements of the actuator speed regulation and compound action, where the work efficiency is higher than that of the three-pump throttling system.

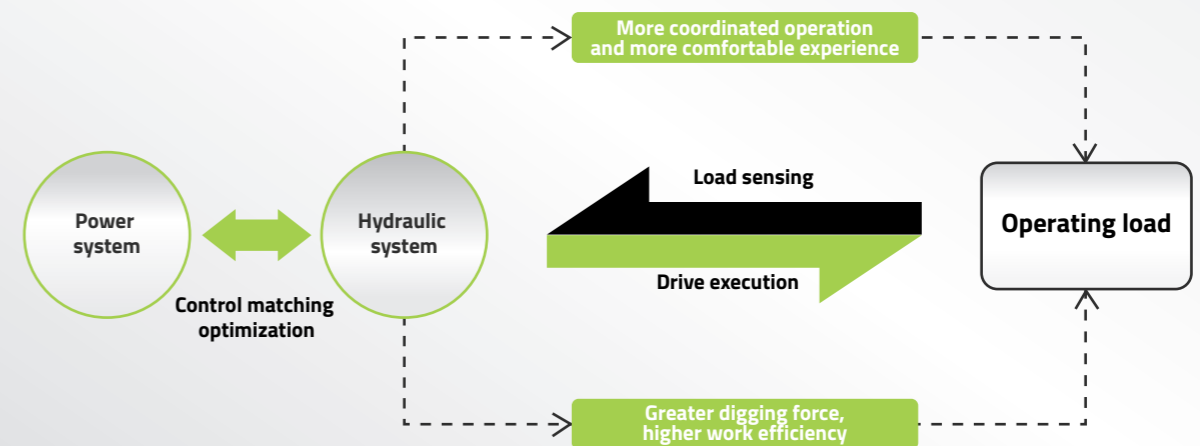

RETRACTABLE TRACK



Retractable track, so that the width of the machine is adjustable from 990 mm to 1240mm. In a narrow working space, the track shrinks so that the width of the whole machine becomes smaller, and the passability is better.

CONTROL PANEL

The LCD instrument panel provides key control. The user-friendly operation panel is not only full of technology, but also retains the physical key touch feeling. The menu bar on the right allows you to view key information such as engine speed, coolant temperature, and fuel level.



1. Battery voltage	2. Working hours	3. Hydraulic oil temperature	4. Fuel quantity
5. Fault warning	6. Menu bar	7. Mode switching	8. Light
9. Alarm			

ROPS/FOPS CANOPY

Safety is our primary concern. The canopy meets ROPS (Roll-Over Protective Structure) and FOPS (Falling Objects Protective Structure) requirements. This is in line with our "people-oriented" concept to provide customers with a good working environment and improve work efficiency.

SMOOTH THROTTLE

The push rod outside the right armrest box is the throttle push rod (pushing forward to reduce the throttle, pulling back to increase the throttle).

ELECTRIC PROPORTIONING JOYSTICK FOR A HIGH-CONFIGURATION MACHINE

The electric proportional joystick of a high configuration machine can better assist customers in controlling various attachments to complete various tasks.



Adjustable armrest, which perfectly matches with the joystick, letting the operator work in the most comfortable posture with high efficiency.

ADJUSTABLE ARMREST



BOOM CYLINDER PROTECTION

Different from the traditional boom cylinder position, the boom cylinder of ZE18GU is located above the boom to provide protection for the boom cylinder. This design avoids the stone splash damage to the cylinder especially in the breaking work.



OPEN INSPECTION

You can check the hydraulic system through the window by lifting the cab foot pad and opening the bottom plate, without the need to remove and tighten bolts or take other actions.



FRAGILE COMPONENTS PROTECTION

The working piping and boom harness are built in to protect these fragile components from damage.



EASY FILLING

By opening the cover plate, you can easily fill hydraulic oil and diesel here.



ONE-STOP MAINTENANCE

To open the whole tail covering piece, you only need to gently press the lock and rotate the buckle. All maintenance parts are within reach, maintenance space is large, and the maintenance method is simple, which greatly reduces the maintenance time and increases the work efficiency.



ZE18GU	
DIMENSIONS	
Overall length A	3545 mm
Overall width B	990/1240 mm
Overall height C	2385 mm
Track gauge D	760/1010 mm
Length of track on ground E	1230 mm
Tail swing radius F	620 mm
Counterweight ground clearance G	450 mm
Minimum ground clearance H	150 mm
PERFORMANCE PARAMETERS	
Operating weight	1800 kg
Standard bucket capacity	0.04 m ³
Rated power	11.8 kW@2300 rpm
Travel speed (high/low)	3.8/2.2 km/h
Swing speed	10 r/min
WORK RANGE	
Max. digging reach A'	3910 mm
Max. digging reach at ground level B'	3845 mm
Max. digging depth C'	2316 mm
Max. vertical digging depth D'	1910 mm
Max. digging height E'	3542 mm
Minimum front swing radius F'	1538 mm



ZE18GU	
HYDRAULIC SYSTEM	
Main pump	Maximum displacement : 62.5 L/min
Working oil circuit	24.8 MPa
Swing oil circuit	16.2 MPa
Traveling oil circuit	20.6 MPa
Pilot oil circuit	3.5 MPa
BASIC TECHNICAL DATA	
Digging force of bucket (ISO)	17 kN
Digging force of arm (ISO)	10 kN
Max. drawbar pull	18 kN
Boom length	1830 mm
Arm length	950 mm
AMOUNT OF FILLING FOR MAINTENANCE	
Fuel tank capacity	20 L
Engine coolant	0.5 L
Engine oil	3.7 L
Hydraulic system	25 L
Hydraulic tank	18 L

LIFT CAPACITY

LIFT POINT HEIGHT	Lift Point Radius (1.5 m)		Lift Point Radius (2 m)		Lift Point Radius (MAX)	
	over-front (kg)	over-side (kg)	over-front (kg)	over-side (kg)	over-front (kg)	over-side (kg)
2.0 m			280*	280		
1.5 m	450*	450	400*	320	320*	180
1.0 m			550*	310	320*	170
0 m			580*	290	320*	170
-0.5 m	700*	430	500*	280		
-1.5 m	460*	440	310*	280		

Notes:

1. Load with * is limited by hydraulic capacity and based on ISO10567. Rated loads do not exceed 87% of the hydraulic capacity.
2. Load without * is limited by tipping load and based on ISO10567. Rated loads do not exceed 75% of the tipping capacity.
3. The excavator bucket, hook, sling and other lifting accessories are not included in this table.

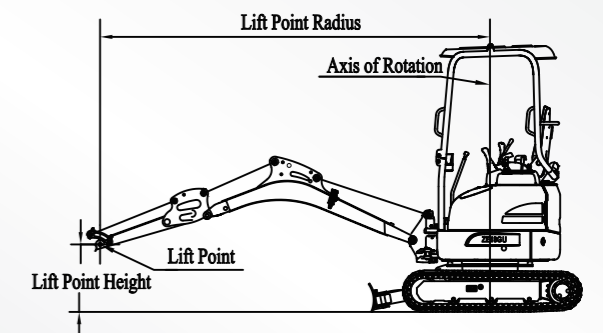

SYSTEM	CONFIGURATION ITEM	ZE18GU
Powertrain	Engine	● Kubota
	Emissions from engine	Euro 5/T4F
	Power kW/rpm	11.8/2300
Hydraulic system	Air Filter	●
	Boom cylinder hose burst valve	●
	Arm cylinder hose burst valve	●
	Breaker plumbing (one/two-way switchable)	●
	Attachment plumbing	●
	Quick coupler plumbing	●
Cab	Flow regulation attachment plumbing	●
	Canopy	●
	FOPS	●
	ROPS	●
Lower structure	Fire extinguisher	○
	Multifunctional joystick	●
	Two-bar steel crawler	○
	Rubber track	●
	Rubber track block	○230 mm
	230mm track	●
	Carrier roller, single side	● Single carrier roller
Track roller, single side	● 3	
Work equipment	Lower rail damp, single side	○ Single guard rail
	Bulldozer blade	●
	Standard boom length	● 1830 mm
	Standard arm length	● 950 mm
Bucket	Arm for thumb damp	○ 950 mm
	Standard configuration	● 0.04 m ³ reinforced bucket
	Optional part 1	○ 300 mm narrow bucket
Electrical system	Optional part 2	○ 900 mm wide flat bucket
	Audible and visual alarm	●
	Emergency stop switch	●
	12V power port	●
	Boom working light	● 1
Attachments	GPS	●
	Recommended breaker drill rod diameter 1	45 mm
	Straight breaker	○
	Hydraulic quick coupler	○
	Ripper	○
	Tilt soil bucket	○
	Auger (with 300mm drill bit)	○
Auger extension rod	○ 600 mm	
Others	Auger bit 450mm	○
	Thumb clamp	○
	Auxiliary counterweight	○
	Cab rearview mirror	○ 1

● STANDARD ○ OPTIONAL

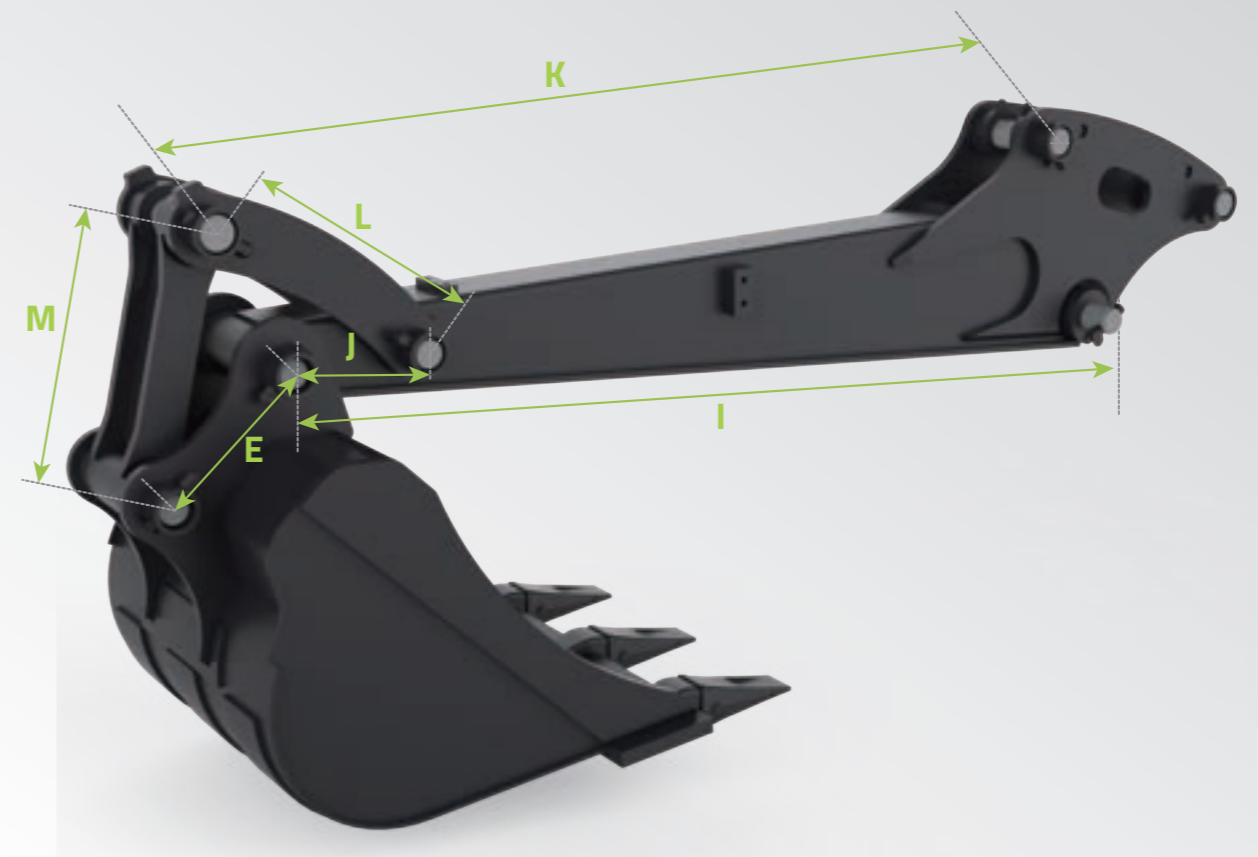

Unit: mm

MODEL	A	B	C	D	E	F	G	H	I
ZE18GU	96	96	30	30	100	175	47	25	950

MODEL	J	K	L	M
ZE18GU	85	798	176	176