

**ZOOMLION**

# ***FD50-70Z***

**INTERNAL COMBUSTION  
FORKLIFT**



 The color combination has obtained the protection of registered trademark

## **PRODUCT CHARACTERISTICS**

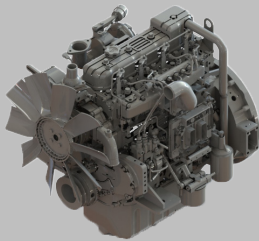

Engine is with large torque and capacity, which is powerful and can meet different operation demands.



Integrated overhead guard is adopted. The canopy is one time stamping part with 5 pieces transparent plastic cover, which receives sufficient light and keeps rain out.

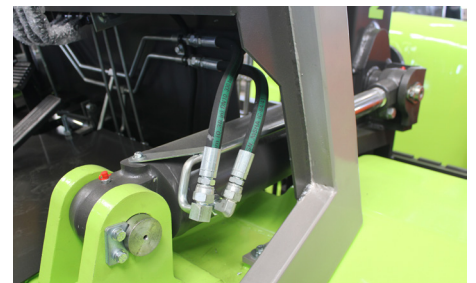

Hydraulic system is equipped with the throttling valve, which makes operation safe and reliable.



Reinforce mast with wide view design improves efficiency and safety meanwhile enhances anti-forde capacity.



Scientific ergonomic design makes more portable and comfortable. Seat and backrest are adjustable.



Steering wheel tilt angle is also adjustable, which leaves more legroom. The portable gearshift is quick to shift and easy to operate.

The company reserves the right to modify the parameters provided. In case of material commercial modification information, the following notice shall prevail.

# Machine Parameters

FEATURES		FD50	FD60	FD70
Power	–	Diesel	Diesel	Diesel
Rated Capacity	kg	5000	6000	7000
Center of load	J(mm)	600	600	600
Lifting height	h1 (mm)	3000	3000	3000
Free lifting height	h3(mm)	203	208	218
Forks L×W×H	L5xWxT(mm)	1220×150×55	1220×150×60	1220×150×70
Tilt Forward/Backward	°	6/12	6/12	6/12
Min.turning radius	R(mm)	3415	3507	3507
Min.ground clearance(Mast)	Ra(mm)	5645	5742	5752
ground clearance(Mast)	m(mm)	200	200	200
Overhead guard height	h4(mm)	2460	2460	2460
Front overhang	L3(mm)	610	615	625
Rear overhang	L4(mm)	566	692	692
<b>PERFORMANCE</b>				
Max.traveling speed(loaded)	km/h	26	26	26
Max.lifting speed(loaded/empty)	mm/s	370/450	370/450	350/450
Drawbar pull	kN	51.4	51.4	51.4
Gradeability	%	28	28	28
<b>SIZE</b>				
Overall length (within fork )	L1 (mm)	4736	4877	4877
Overall width	W1 (mm)	2000	2000	2000
Mast lowered height	h2(mm)	4417	4417	4417
Mast extended height	mm	2500	2500	2500
<b>CHASSIS</b>				
Tire Front	–	8.25-15-14PR	8.25-15-14PR	8.25-15-14PR
Tire Rear	–	8.25-15-14PR	8.25-15-14PR	8.25-15-14PR
Wheelbase	L2(mm)	2340	2340	2340
Tread width(Front/Rear)	S/P(mm)	1470/1700	1470/1700	1470/1700
Curb weight(Non-load)	kg	7980	8640	9340
<b>ENGINE</b>				
Battery(Voltage/Capacity)	V/Ah	(12/90)x2	(12/90)x2	(12/90)x2
Engine(Model)	–	Cummins F3.8	Cummins F3.8	Cummins F3.8
Engine(Rated power)	kw/r.p.m	90/2200	90/2200	90/2200
Engine(Rated torque)	N.m/r.p.m	500/1500	500/1500	500/1500
Engine(Cylinder amount)	mm	4	4	4
Engine(Bore × Stroke)	-	102×115	102×115	102×115
Engine(Displacement)	L	3.8	3.8	3.8
Fuel tank	L	140	140	140
Transmission	–	2/2 Manual Shift	2/2 Manual Shift	2/2 Manual Shift
Working pressure	MPa	20	20	20

Remarks:The above parameters are based on 3M duplex standard mast.

Specification Of Optional Engine	Drive Type	Model	Displacement (L)	Rated Power/Speed (kW/r.p.m)
Cummins	Diesel	QSF3.8(Euro 3)	3.8	93/2200
Cummins	Diesel	F3.8(Euro 5)	3.8	90/2200
Isuzu	Diesel	6BG1	6.494	82.4/2200
Yuchai	Diesel	YCA05115- S500(Euro 5)	4.873	85/2200

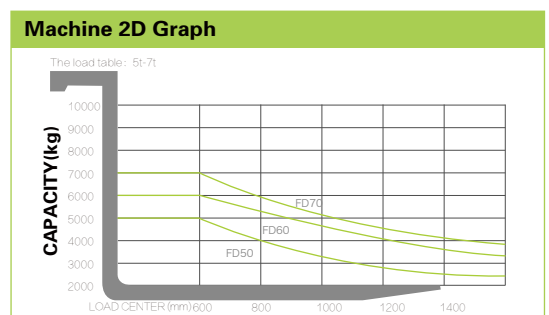
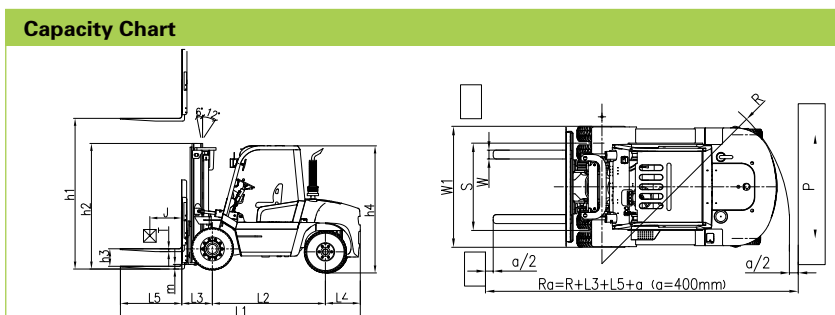

**ZOOMLION MATERIAL HANDLING INTERNATIONAL**

All rights reserved by Zoomlion Heavy Industry Science&Technology Co., Ltd